

LASER

PN

BYSTRONIC

MATE[®]
M
**PRECISION
TECHNOLOGIES**
RESPECT • SUPPORT • INSPIRE



High Performance Laser Consumables

BYSTRONIC[®]

CO2 & FIBER LASER

- NOZZLES
- OPTICS
- ACCESSORIES



Headquartered in Anoka, Minnesota, in a 300,000 sq. ft. (28,000m²) state-of-the-art facility.

SEVEN DECADES OF EXCELLENCE

Founded in 1962, Mate is a world-class manufacturer of superior solutions for the metal cutting and metal forming industries. We manufacture workholding systems, CNC punch press tooling, and offer a complete line of press brake tooling and laser consumables. Mate products and services are available worldwide, fully supported by more than 80 dealers in every industrialized country.

PERSONAL, RESPECTFUL RELATIONSHIPS

Mate does business with people, not companies. Our connection to you is personal. Mate's team of manufacturing and metalworking professionals knows what you go through. We know what it's like to compete for that next job, manage deadlines or even need a rescue. With Mate you have a partner that respects your knowledge and is dedicated to helping you succeed.

YOUR GO-TO SOURCE

Serving our customers is at the core of who we are. In your plant or on the phone, we're up for whatever metalworking challenges you face. Your Mate representatives are experts who know from experience what happens on the shop floor and provide our legendary in-field support. They speak your language, fully capable of helping you improve processes and solve problems. Mate customer service is ready to assist with fast quotes, guiding your order on to our top-notch machinists and shipping pros.

GET INSPIRED!

With our vast knowledge and broad product range we inspire innovative thinking. Our customer's projects can be seen around the world: from unique building façades thought to be impossible to make, to a new way to add strength to thin material. The possibilities are endless, so think big, bold and beyond.

WE'VE GOT YOU COVERED

Dedicated to quality in every aspect of our business, Mate offers an extensive standard product line that can be delivered with same day or next day service. All Mate products are backed with our industry leading 100% customer satisfaction guarantee.



MATE'S MISSION AND PROMISE TO YOU:

Mate's mission is to personally **Respect, Support** and **Inspire** metalworking professionals around the world with high-quality products and services for factory productivity.

[Dimensions in Inches (mm)]



PERFORMAX™

Performax™ CO2 Laser Lenses (MLL Series)

MATE PERFORMAX™ – the production lens for consistent CO2 laser performance

- Ideal for general laser cutting 4Kw and less
- Rated at less than 0.20% absorption, among the lowest standard lenses on the market
- Superior polishing for a smoother, easier to clean surface. Polished to a 20/10 scratch/dig specification to resist spatter and stay clean longer



PEAK™

Low Absorption CO2 Laser Lenses (MLP Series)

The difference is clear: MATE PEAK™ low absorption, high performance CO2 laser lenses for demanding applications or high power cutting

- Less than 0.15% absorption offers improved cut quality, consistency and longer lens life
- Helium Neon (HeNe) laser beam compatible for better part alignment
- Proprietary clear coating offers superior lens stability, and allows for lens inspection and stress analysis
- Reduces optical distortion and focal length shift



BLACKMAGIC™

Low Absorption CO2 Laser Lenses (MLB Series)

- Increased Performance and Versatility: Produce improved cuts on aluminum, stainless and other materials
- Coating: Black Magic lenses have the most durable coating in the industry and are spatter resistant
- Impervious to humidity: Work well regardless of humidity for assured efficiency
- Cost Savings: Usually last twice as long or more as standard lenses



1 MICRON OPTICS

Fiber Laser Optics (MLF and MLW Series)

- Lower absorption for maximum cut quality and extended optic life
- Clear coating offers superior lens stability
- Consistent performance: manufactured to exceptionally high tolerances for consistent performance and uniform cutting
- Approved by leading OEMs



FLOWMASTER™

Nozzles and Nozzle Holders (MLN Series)

MATE FLOWMASTER™ nozzles are available in single and double style

- Highest quality copper alloy, stainless and hard stainless material
- Precision manufactured to tight tolerances of +/- 0-10 microns
- Micro-finished internal surfaces improve airflow
- Available for most OEM laser machine manufacturers
- Mate® carries over 2000 types of laser MLN nozzles and nozzle holders
- Manufactured to exacting standards to eliminate unnecessary variables and costly cutting problems for maximum productivity



[Dimensions in Inches (mm)]

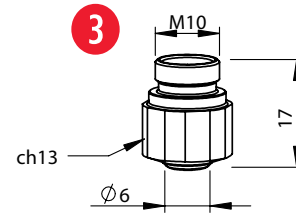
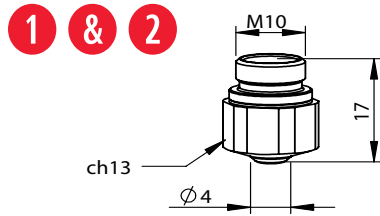

GAS	POS	MATE PART NUMBER	OEM CODE	ALTERNATE CODE	PART DESCRIPTION
NITROGEN-THREADED	1	MLN00634	3-04277 HK08	L674	SINGLE - 0.8MM HD NOZZLE
		MLN00099	3-01910 HK10	L72	SINGLE - 1.0MM HD NOZZLE
		MLN00100	3-01911 HK12	L121	SINGLE - 1.25MM HD NOZZLE
		MLN00101	3-01912 HK15	L73	SINGLE - 1.5MM HD NOZZLE
		MLN00102	3-01913 HK17	L122	SINGLE - 1.75MM HD NOZZLE
		MLN00467	3-01910 HK10	L72X	SINGLE - 1.0MM HD NOZZLE CHROME
		MLN00468	3-01911 HK12	L121X	SINGLE - 1.25MM HD NOZZLE CHROME
		MLN00469	3-01912 HK15	L73X	SINGLE - 1.5MM HD NOZZLE CHROME
		MLN00470	3-01913 HK17	L122X	SINGLE - 1.75MM HD NOZZLE CHROME
	2	MLN00093	3-04273 K08	L83	SINGLE - 0.8MM NOZZLE
		MLN00094	3-01905 K10	L116	SINGLE - 1.0MM NOZZLE
		MLN00095	3-01906 K12	L117	SINGLE - 1.25MM NOZZLE
		MLN00096	3-01907 K15	L118	SINGLE - 1.5MM NOZZLE
	OXYGEN-THREADED	3	MLN00103	3-01914 HK20	L123
MLN00104			3-03854 HK25	L140	SINGLE - 2.5MM HD NOZZLE
MLN00106			3-06112 HK30	L265	SINGLE - 3.0MM HD NOZZLE
MLN00471			3-01914 HK20	L123X	SINGLE - 2.0MM HD NOZZLE CHROME
MLN00472			3-03854 HK25	L140X	SINGLE - 2.5MM HD NOZZLE CHROME
MLN00473			3-06112 HK30	L265X	SINGLE - 3.0MM HD NOZZLE CHROME

[Dimensions in Inches (mm)]

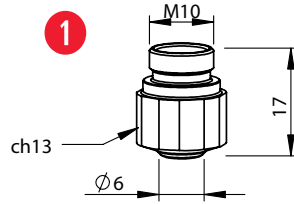

GAS	POS	MATE PART NUMBER	OEM CODE	ALTERNATE CODE	PART DESCRIPTION
OXYGEN - THREADED	1	MLN01081	3-16058 NK10 - 15	L1363	DOUBLE - 1.0MM NOZZLE
		MLN01082	3-16059 NK12- 15	L1364	DOUBLE - 1.25MM NOZZLE
		MLN01083	3-16060 NK15- 15	L1365	DOUBLE - 1.5MM NOZZLE
		MLN01084	3-14317 NK17 - 15	L1366	DOUBLE - 1.75MM NOZZLE
		MLN01085	3-14318 NK20 - 15	L604	DOUBLE - 2.0MM NOZZLE
		MLN01086	3-14319 NK25 - 15	L605	DOUBLE - 2.5MM NOZZLE
		MLN01521	3-16256 NK25 - 20	L612	DOUBLE - 2.5MM NOZZLE
		MLN01087	3-16061 NK30 - 17	L613	DOUBLE - 3.0MM NOZZLE
		MLN01522	3-16257 NK30 - 20	L606	DOUBLE - 3.0MM NOZZLE
		MLN01088	NK35-30	L607	DOUBLE - 3.5MM NOZZLE
		MLN0152310	3-16058 NK10 - 15	L301363X	DOUBLE - 1MM NOZZLE CHROME (10 PK ONLY)
		MLN0152410	3-16059 NK12- 15	L301364X	DOUBLE - 1.25MM NOZZLE CHROME (10 PK ONLY)
		MLN0152510	3-16060 NK15- 15	L301365X	DOUBLE - 1.5MM NOZZLE CHROME (10 PK ONLY)
		MLN0152610	3-14317 NK17 - 15	L301366X	DOUBLE - 1.75MM NOZZLE CHROME (10 PK ONLY)
		MLN00499	3-14318 NK20 - 15	L604X	DOUBLE - 2MM NOZZLE CHROME
		MLN00498	3-14319 NK25 - 15	L605X	DOUBLE - 2.5MM NOZZLE CHROME
		MLN0049810	3-14319 NK25 - 15	L30605X	DOUBLE - 2.5MM NOZZLE CHROME (10 PK ONLY)
		MLN00637	3-16256 NK25 - 20	L612X	DOUBLE - 2.5MM NOZZLE CHROME
		MLN00638	3-16061 NK30 - 17	L613X	DOUBLE - 3MM NOZZLE CHROME

[Dimensions in Inches (mm)]

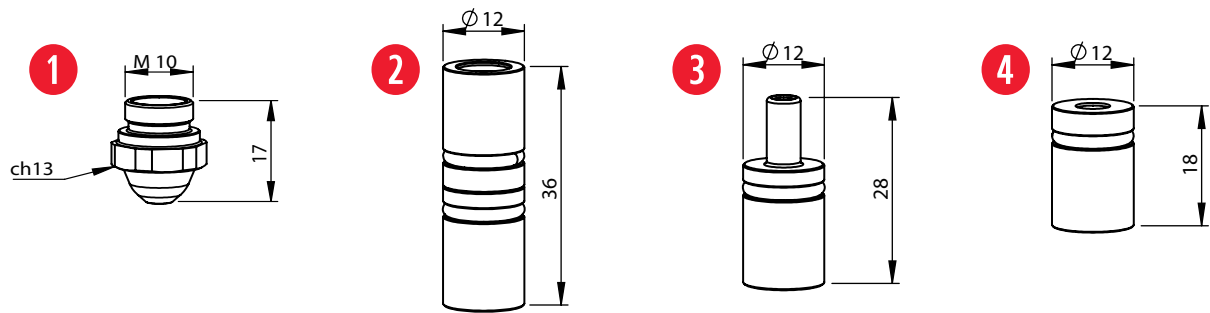

POS	MATE PART NUMBER	OEM CODE	ALTERNATE CODE	PART DESCRIPTION
1	MLN00135	3-01899 H10	L88	SINGLE - 1.0MM NOZZLE HD
	MLN00136	3-01900 H12	L103	SINGLE - 1.25MM NOZZLE HD
	MLN00137	3-01901 H15	L104	SINGLE - 1.5MM NOZZLE HD
	MLN00138	3-01902 H17	L105	SINGLE - 1.75MM NOZZLE HD
	MLN00139	3-01903 H20	L106	SINGLE - 2.0MM NOZZLE HD
	MLN00641	3-04276 H25	L677	SINGLE - 2.5MM NOZZLE HD
	MLN00642	3-01899 H10	L88X	SINGLE - 1.0MM NOZZLE HD CHROME
	MLN00643	3-01900 H12	L103X	SINGLE - 1.25MM NOZZLE HD CHROME
	MLN00644	3-01901 H15	L104X	SINGLE - 1.5MM NOZZLE HD CHROME
	MLN00645	3-01902 H17	L105X	SINGLE - 1.75MM NOZZLE HD CHROME
	MLN00646	3-01903 H20	L106X	SINGLE - 2.0MM NOZZLE HD CHROME
	MLN00647	3-04276 H25	L677X	SINGLE - 2.5MM NOZZLE HD CHROME
	MLN01529	H30	L679X	SINGLE - 3.0MM NOZZLE HD CHROME
	2	MLN01142	7023207, 7023208	AL418
3	MLN01236	7023207	AL416	WATER CONNECTOR, MALE
4	MLN01237	7023208	AL417	WATER CONNECTOR, FEMALE

[Dimensions in Inches (mm)]



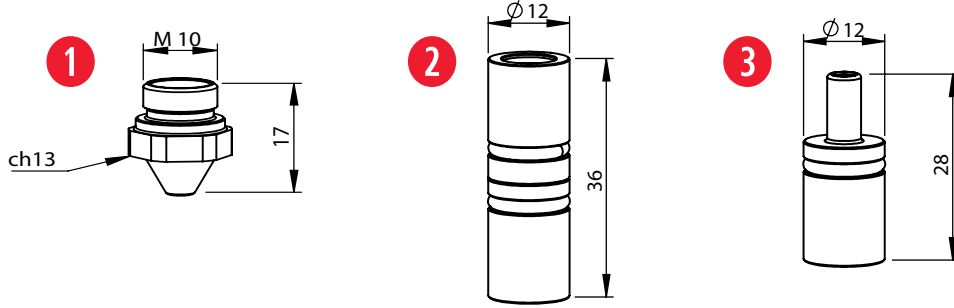

POS	MATE PART NUMBER	OEM CODE	ALTERNATE CODE	PART DESCRIPTION
1	MLN00119	3-01894 10	L14	SINGLE - 1.0MM NOZZLE
	MLN00126	3-01901 H15	L44	SINGLE - 1.5MM NOZZLE HD
	MLN00127	3-01902 H17	L45	SINGLE - 1.75MM NOZZLE HD
	MLN00128	3-01903 H20	L46	SINGLE - 2.0MM NOZZLE HD
2	MLN01142	7023207, 7023208	AL418	WATER CONNECTOR SET
3	MLN01236	7023207	AL416	WATER CONNECTOR, MALE

[Dimensions in Inches (mm)]

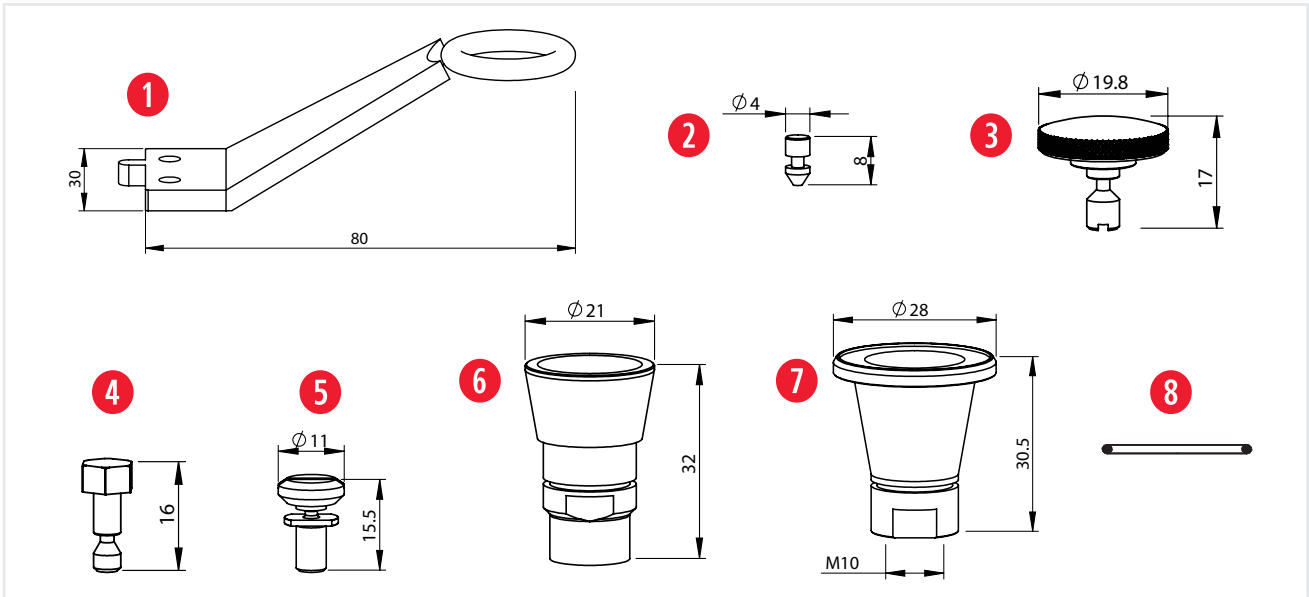

POS	MATE PART NUMBER	OEM CODE	ALTERNATE CODE	PART DESCRIPTION
1	MLN00089	2-01262	AL5	SCANNER
2	MLN00086	4-03137	AL24	PIN
3	MLN00084	4-03136	AL25	KNURLED SCREW - BRASS
4	MLN00088	4-00324	AL1	KNURLED SCREW
5	MLN00648	3-09001	AL208	SCREW FOR CROSS-JET
6	MLN00553	3-02291	AL188	NOZZLE BODY CAPACITIVE
7	MLN00087	3-05497	AL102	NOZZLE BODY - COPPER
8	MLN00660	3141122	AL226	O'RING FOR NOZZLE
NOT SHOWN	MLN00662	3140236	3140236	O'RING FOR NOZZLE
	MLN00657	3140820	AL99	O'RING FOR LENS
NOT SHOWN	MLN00653		AL246	SCREWS KIT FOR MLN00652

[Dimensions in Inches (mm)]

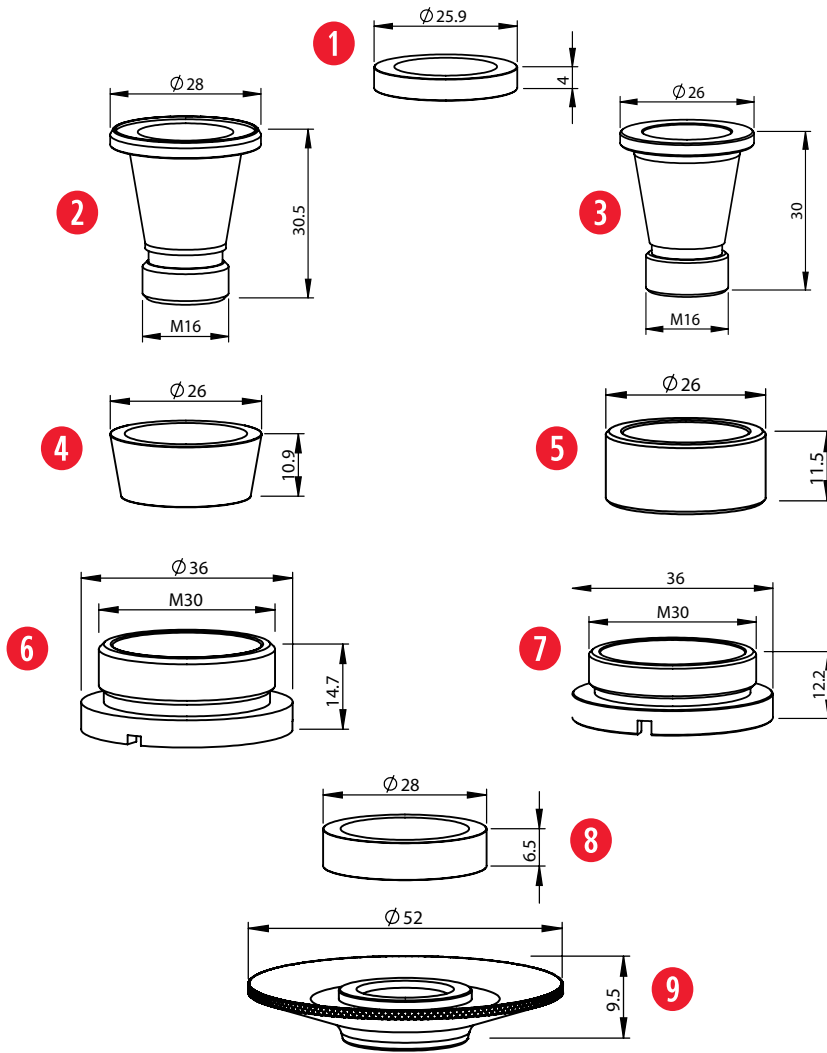

POS	MATE PART NUMBER	OEM CODE	ALTERNATE CODE	PART DESCRIPTION
1	MLN00091	4-01642	AL125	INSULATING DISC - CERAMIC
	MLN00649	4-01642	AL231	INSULATING DISC NEW VERSION - CERAMIC
2	MLN00489	2-08701, 3-05497	AL172	NOZZLE BODY
3	MLN01140	10032930, 5000839396	AL423	NOZZLE BODY
4	MLN00092	4-01959	AL124	CONE - CERAMIC
	MLN00650	4-01959	AL230	CONE -NEW VERSION - CERAMIC
5	MLN01141	10032838	AL425	INSULATING RING - CERAMIC
6	MLN00529	3-11071	AL174	FASTENING NUT
7	MLN01143	10032839	AL424	FASTENING NUT
8	MLN00491	4-09010	AL126	INSULATING RING - CERAMIC
9	MLN00490	2-08700	AL173	THREADED SIGNBOARD
	MLN01530	2-08700	AL173X	SIGNBOARD - CHROME

[Dimensions in Inches (mm)]

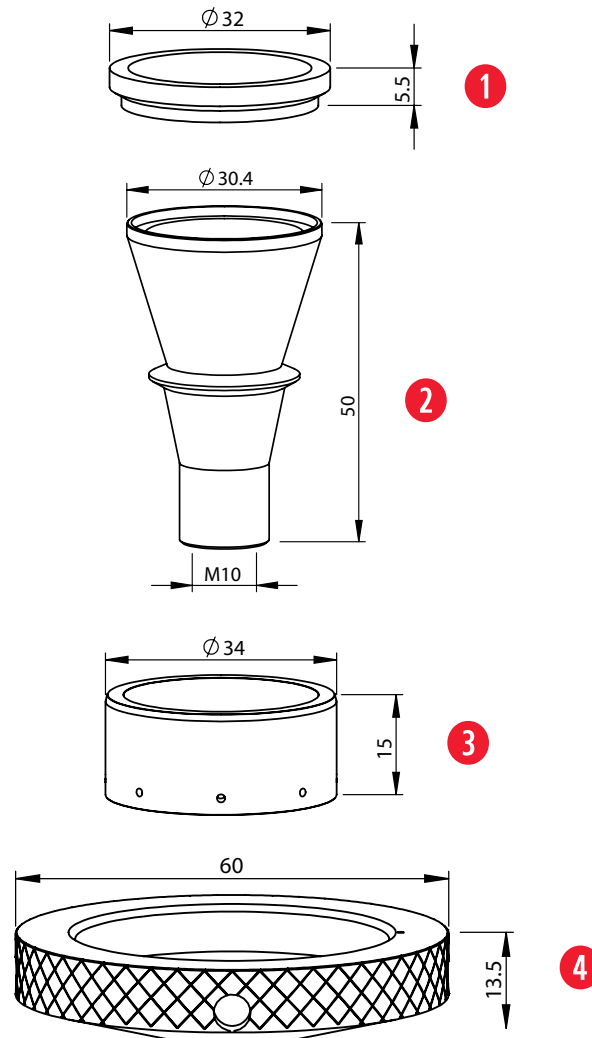

POS	MATE PART NUMBER	OEM CODE	ALTERNATE CODE	PART DESCRIPTION
1	MLN00591	3-13113	AL215	INSULATING RING WITH HOLES
2	MLN00590	2-10837	AL214	NOZZLE BODY
3	MLN00592	3-13422	AL216	INSULATING RING
4	MLN00966	3-13110	AL258	SHIELD - COPPER

[Dimensions in Inches (mm)]

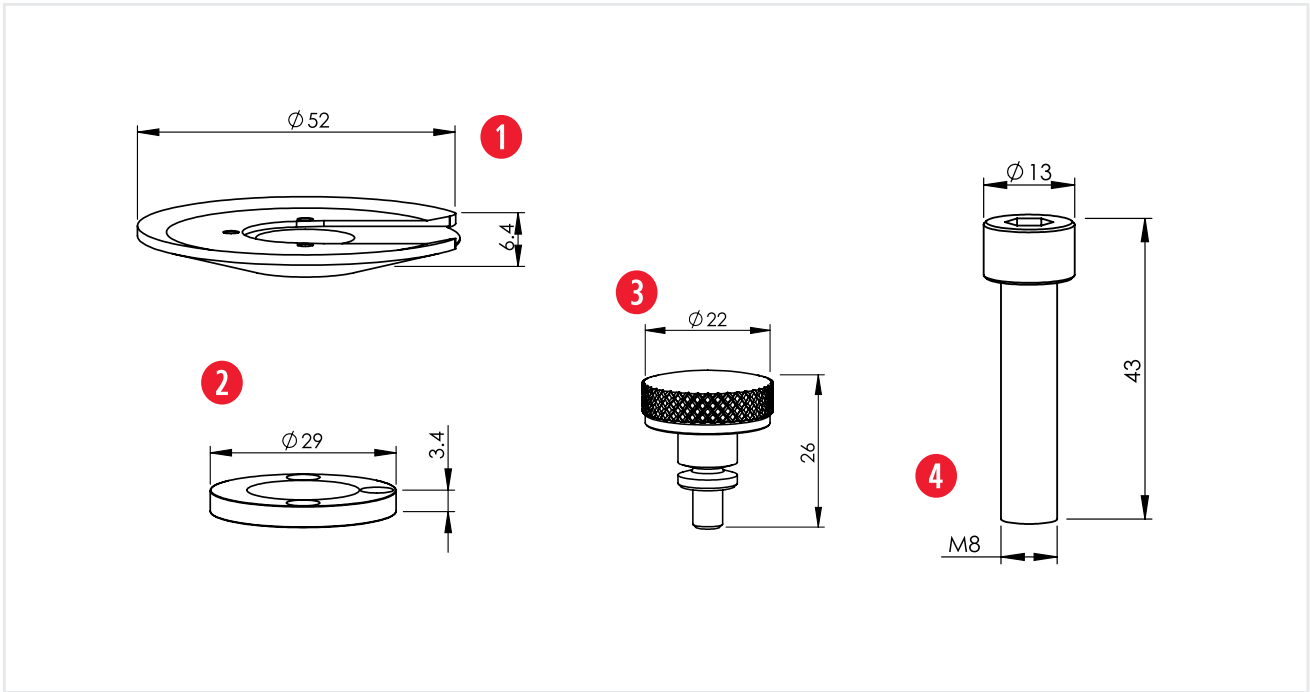

POS	MATE PART NUMBER	OEM CODE	ALTERNATE CODE	PART DESCRIPTION
1	MLN00654	3-06035	AL222	SIGNBOARD - COPPER ONLY
2	MLN00090	3-06035-T	AL120	DISC - PTFE
3	MLN00658	4-04976	AL209	KNURLED SCREW
4	MLN01536	333884	333884	PLASTIC SCREWS - 2pcs

[Dimensions in Inches (mm)]

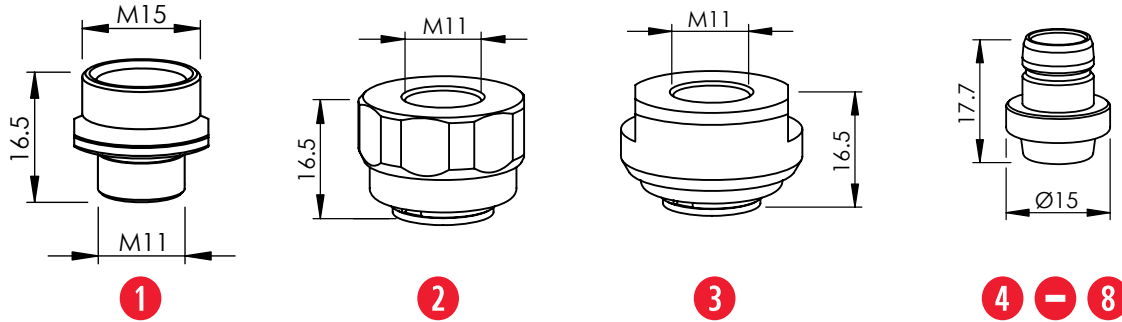

POS	MATE PART NUMBER	OEM CODE	ALTERNATE CODE	PART DESCRIPTION
1	MLN02154	10075057	AL453	BREAKAWAY
2	MLN02155	10074594	AL448	PUSH FIT NOZZLE HOLDER
3	MLN02156	10077009	AL548	PUSH FIT NOZZLE HOLDER
	MLN02157	10083262	AL592	PUSH FIT NOZZLE HOLDER & BREAKAWAY
4	MLN01202	10048529 - HK8	L301660	SINGLE - 0.8MM PUSH FIT NOZZLE (10PK)
	MLN01187	10035266 - HK10	L301661	SINGLE - 1.0MM PUSH FIT NOZZLE(10PK)
	MLN01188	10035267 - HK12	L301662	SINGLE - 1.2MM PUSH FIT NOZZLE(10PK)
	MLN01189	10035268 - HK15	L301663	SINGLE - 1.5MMPUSH FIT NOZZLE (10PK)
	MLN01364	10035269 - HK17	L301664	SINGLE - 1.7MM PUSH FIT NOZZLE(10PK)
	MLN01190	10035270 - HK20	L301665	SINGLE - 2.0MM PUSH FIT NOZZLE(10 PK)
	MLN01365	1007175, 10035271, HK25	L301666	SINGLE - 2.5MM PUSH FIT NOZZLE(10PK)
	MLN01191	10035272 - HK30	L301667	SINGLE - 3.0MM PUSH FIT NOZZLE(10PK)
	MLN01366	10049744 - HK35	L301668	SINGLE - 3.5MM PUSH FIT NOZZLE(10PK)
5	MLN01367	10049747 - NK1015	L301670	DOUBLE - 1.0MM PUSH FIT NOZZLE (10PK)
	MLN01192	10035275 - NK1215	L301671	DOUBLE - 1.2MM PUSH FIT NOZZLE (10PK)
	MLN01193	10035278 - NK1515	L301672	DOUBLE - 1.5MM PUSH FIT NOZZLE (10PK)
	MLN01368	10035290 - NK1715	L301673	DOUBLE - 1.7MM PUSH FIT NOZZLE (10PK)

[Dimensions in Inches (mm)]



(continued)

POS	MATE PART NUMBER	OEM CODE	ALTERNATE CODE	PART DESCRIPTION
	MLN01194	10035292 - NK2015	L301674	DOUBLE - 2.0MM PUSH FIT NOZZLE (10PK)
	MLN01369	10035294 - NK2515	L301675	DOUBLE - 2.5MM PUSH FIT NOZZLE (10PK)
	MLN01201	10035296 - NK2520	L301676	DOUBLE - 2.5MM/INNER 2.0MM PUSH FIT NOZZLE (10PK)
	MLN01370	10035298 - NK3017	L301677	DOUBLE - 3.0MM/INNER 1.7MM PUSH FIT NOZZLE (10PK)
	MLN01535	10035301 - NK3020	L301678	DOUBLE - 3.0MM PUSH FIT NOZZLE (10PK)
	MLN01372	10035302 - NK3530	L301679	DOUBLE - 3.5MM PUSH FIT NOZZLE (10PK)
	MLN02036	10070837, 10068496 - NK3517	L301680	DOUBLE - 3.5MM PUSH FIT NOZZLE (10PK)
	MLN02037	10070839, 10068498 - NK4017	L301681	DOUBLE - 4.0MM PUSH FIT NOZZLE (10PK)
6	MLN01374	10039202	L1682	SINGLE - 2.0MM CENTERING NOZZLE
7	MLN02027	10084700	L302170	SINGLE - 2.0MM F20 DW PUSH FIT NOZZLE (10PK)
	MLN02028	10084701	L302171	SINGLE - 2.5MM F25 DW PUSH FIT NOZZLE (10PK)
	MLN02029	10066333	L302172	SINGLE - 3.0MM F30 DW PUSH FIT NOZZLE (10PK)
	MLN02030	10090091	L302173	SINGLE - 3.5MM F35 DW PUSH FIT NOZZLE (10PK)
	MLN02031	10066331	L302174	SINGLE - 4.0MM F40 DW PUSH FIT NOZZLE (10PK)
	MLN02032	10066330	L302175	SINGLE - 4.5MM F45 DW PUSH FIT NOZZLE (10PK)
	MLN02033	10090092	L302176	SINGLE - 5.0MM F50 DW PUSH FIT NOZZLE (10PK)
	MLN02034	10086053	L302177	SINGLE - 5.5MM F55 DW PUSH FIT NOZZLE (10PK)
	MLN02035	10086069	L302178	SINGLE - 6.0MM F60 DW PUSH FIT MPZZLE (10PK)
	MLN0212810	10084700	L302170X	SINGLE - 2.0MM F20 DW PUSH FIT NOZZLE (10PK)
	MLN0212910	10084701	L302171X	SINGLE - 2.5MM F25 DW PUSH FIT NOZZLE (10PK)
	MLN0213010	10066333	L302172X	SINGLE - 3.0MM F30 DW PUSH FIT NOZZLE (10PK)
	MLN0213110	10090091	L302173X	SINGLE - 3.5MM F35 DW PUSH FIT NOZZLE (10PK)
	MLN0213210	10066331	L302174X	SINGLE - 4.0MM F40 DW PUSH FIT NOZZLE (10PK)
	MLN0213310	10066330	L302175X	SINGLE - 4.5MM F45 DW PUSH FIT NOZZLE (10PK)
	MLN0213410	10090092	L302176X	SINGLE - 5.0MM F50 DW PUSH FIT NOZZLE (10PK)
	MLN0213510	10086053	L302177X	SINGLE - 5.5MM F55 DW PUSH FIT NOZZLE (10PK)
	MLN0213610	10086069	L302178X	SINGLE - 6.0MM F60 DW PUSH FIT MPZZLE (10PK)
	8	MLN02016	10066332, 35H	L1683XH
MLN02017		10068484, 50H	L1684XH	SINGLE - 5.0MM NOZZLE CHROME

[Dimensions in Inches (mm)]

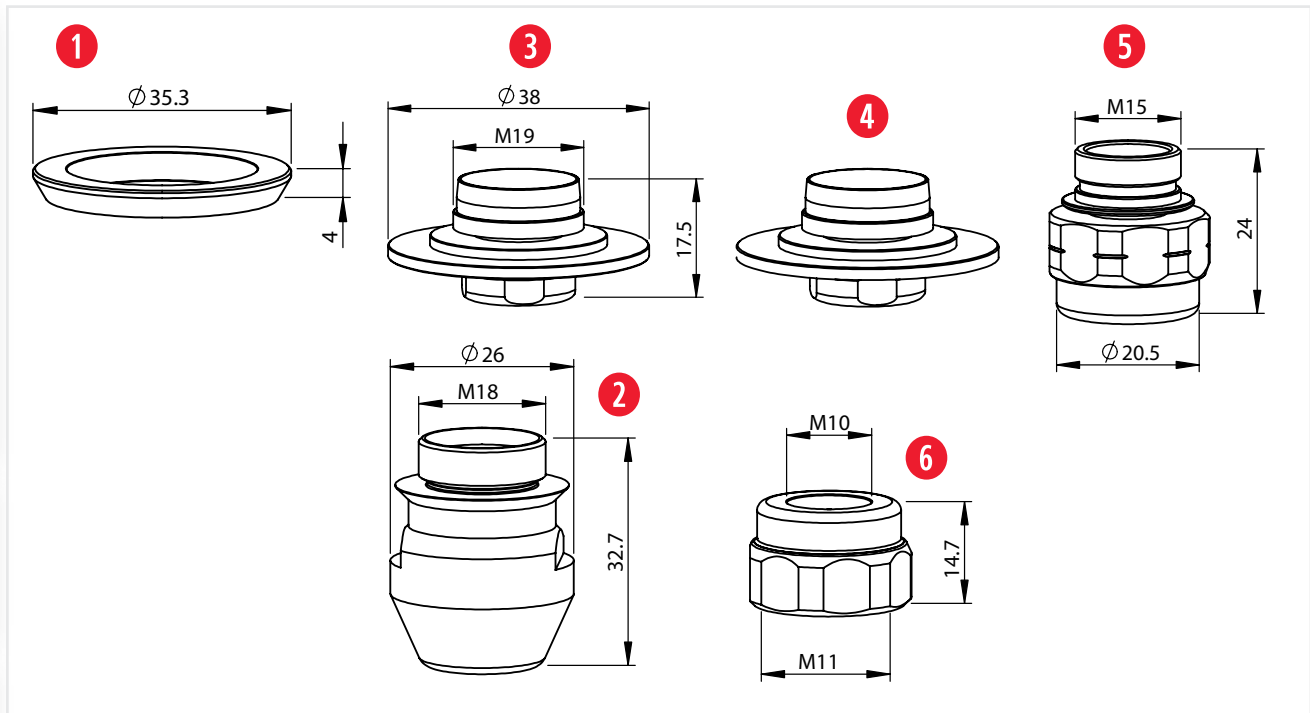

POS	MATE PART NUMBER	OEM CODE	ALTERNATE CODE	PART DESCRIPTION
1	MLN01531	3-13113, 10046025, 08-12-04-9016	AL441	ISOLATOR RING - CERAMIC
2	MLN01183	10034061	AL450	NOZZLE HOLDER
3	MLN01341	10046030	AL451	ADAPTER
4	MLN01181	10064098, 10051133	AL452	ADAPTER Msb
5	MLN01340	10055581, 10064099, 10064098	AL449	NOZZLE BODY
6	MLN02026	10071494, 10083331	AL454	Nozzle body threaded

[Dimensions in Inches (mm)]

PERFORMAX - STANDARD ABSORPTION LENSES					
MATE PART NUMBER	OEM CODE	TYPE	DIAMETER	FOCAL LENGTH	EDGE THICKNESS
MLL00001	4-00186 , 507790	MENISCUS	1.5"	5.0"	0.244"
MLL00002	4-00187-3 , 784964	MENISCUS	1.5"	7.5"	0.244"
MLL00003	4-00185-2	MENISCUS	1.5"	3.75"	0.244"
MLL00004	4-07475, 400187 , 4-05094 , 767963	MENISCUS	1.5"	5.0"	0.354"
MLL00005	698637 , 4-05095 , 570721 , 433792, 4-07476	MENISCUS	1.5"	7.5"	0.354"

PEAK - LOW ABSORPTION LENSES					
MATE PART NUMBER	OEM CODE	TYPE	DIAMETER	FOCAL LENGTH	EDGE THICKNESS
MLP00002	4-00187-3 , 784964 , 714512	MENISCUS	1.5"	7.5"	0.244"
MLP00003	4-00185-2	MENISCUS	1.5"	3.75"	0.244"
MLP00004	400187 , 4-07475-2 , 687087	MENISCUS	1.5"	5.0"	0.354"
MLP00005	698637 , 4-05095 , 570721 , 433792, 4-07476	MENISCUS	1.5"	7.5"	0.354"

BLACK MAGIC- LOW ABSORPTION LENSES					
MATE PART NUMBER	OEM CODE	TYPE	DIAMETER	FOCAL LENGTH	EDGE THICKNESS
MLB00001	4-00186 , 507790	MENISCUS	1.5"	5.0"	0.244"
MLB00002	4-00187-3 , 784964	MENISCUS	1.5"	7.5"	0.244"
MLB00003	4-00185	MENISCUS	1.5"	3.75"	0.244"
MLB00004	400187 , 4-05094 , 767963, 4-07476	MENISCUS	1.5"	5.0"	0.354"
MLB00005	698637 , 4-05095 , 570721 , 433792, 4-07476	MENISCUS	1.5"	7.5"	0.354"

FIBERSHIELD - FIBER LASER PROTECTIVE WINDOWS					
MATE PART NUMBER	OEM CODE	TYPE	DIAMETER	EDGE THICKNESS	
MLW00014	968752 , 1004574691 , 10045746 , 5000740855 , 5000697866 , 10,02.01.5511, 5000959802, 0397023594	FUSED SILICA	36.0mm	5.0mm	
MLW00025	10046110	FUSED SILICA	24.0mm	5.0mm	
MLW00033	10145862, 10145862, 10086368	SAPPHIRE	34.0	3.0mm	

OPTICS CARE	
MATE PART NUMBER	DESCRIPTION
MLN00570	1.5" Polarizer Filter
MLN00582	Lensmate Cleaning Paper - Booklet 4x6 Sheets
MLN01104	Wet Cleaning Wipes - 24 Pack
MLN01105	Cleaning Holder w/ 1.5" Polarizer Filter
MLN01106	Cleaning Holder w/ 2.0" Polarizer Filter
MLN01483	Lens / Mirror Cleaning Base
MLN01996	Optical Cleaning Fluid - Spray
MLN01997	Lens Cleaning Paper - 50 Sheets
MLN01998	4x4 Polyester Wipes - 100 Pack
MLN02000	Lens Cleaning Swabs - 25 Pack

[Dimensions in Inches (mm)]





MATE PRECISION TECHNOLOGIES GLOBAL COVERAGE

WORLDWIDE HEADQUARTERS:

1295 Lund Boulevard, Anoka, Minnesota 55303 USA
Tel +1.763.421.0230 mate.com

orders@mate.com